

# Ethylene Oxide Gas Sensor

Product Data Sheet  
Model #SS21ETO

2025. Ver 1.0

## Applications & Features

- Ideal for fixed instruments
- Industrial safety for chemical production
- Sterilization process



## Specifications

Performance Characteristics	
Output Signal	270±70 nA / ppm
Typical Baseline Range (pure air, @ 20°C)	≤ ±0.5 ppm C <sub>2</sub> H <sub>4</sub> O equivalent
Response Time (T90)	< 200 seconds
Filter	None
Measurement Range	0-20 ppm
Maximum Overload	100 ppm
Linearity	Linear
Repeatability	< ±5% of signal
Recommended Load Resistor	10 ohms
Resolution (Electronics Dependent)	< 0.5 ppm typical
Bias Voltage	+300 mV
Environmental	
Temperature Range Continuous	-20°C to +50°C
Pressure Range	800 to 1200 mbar
Operating Humidity Range	15% to 90% RH
Lifetime	
Long Term Output Drift	< 2% per annum
Recommended Storage Temp	0°C to 20°C
Expected Operating Life	> 24 months in air
Standard Warranty	24 months from date of dispatch
Intrinsic Safety Data	
Maximum at 100 ppm	50 µA
Maximum o/c Voltage	< 1.0 V
Maximum s/c Current	< 0.1 A

## Dimension

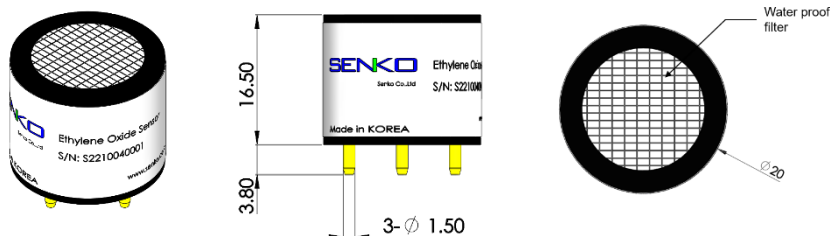

Due to ongoing research and product improvement, specifications are subject to change without notice.

## Temperature Effects

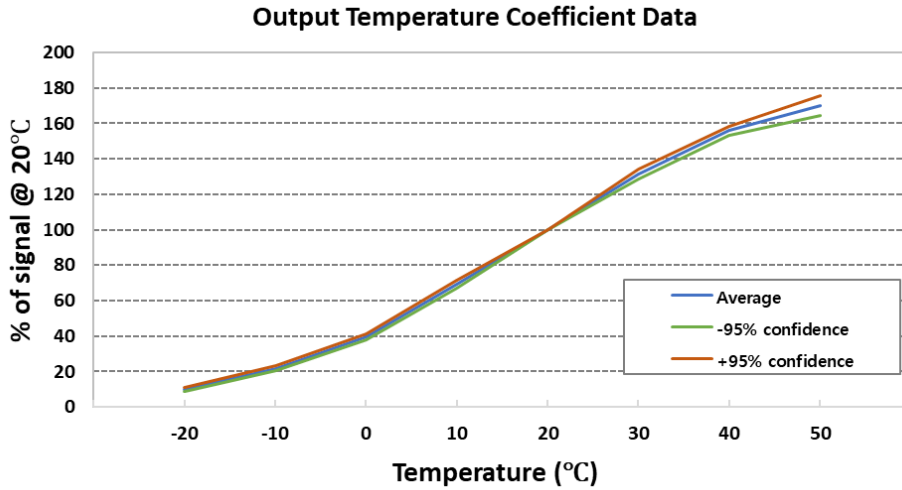

## Cross Sensitivity

Gas	Concentration [ppm]	Reading [ppm]
Ethylene Oxide	5	5
Carbon Monoxide	100	50
Hydrogen	500	< 2
Ammonia	100	0
Ethanol	207	140
Vinyl Chloride	10	8
Toluene	5	0.2

## Standard Operating Circuit

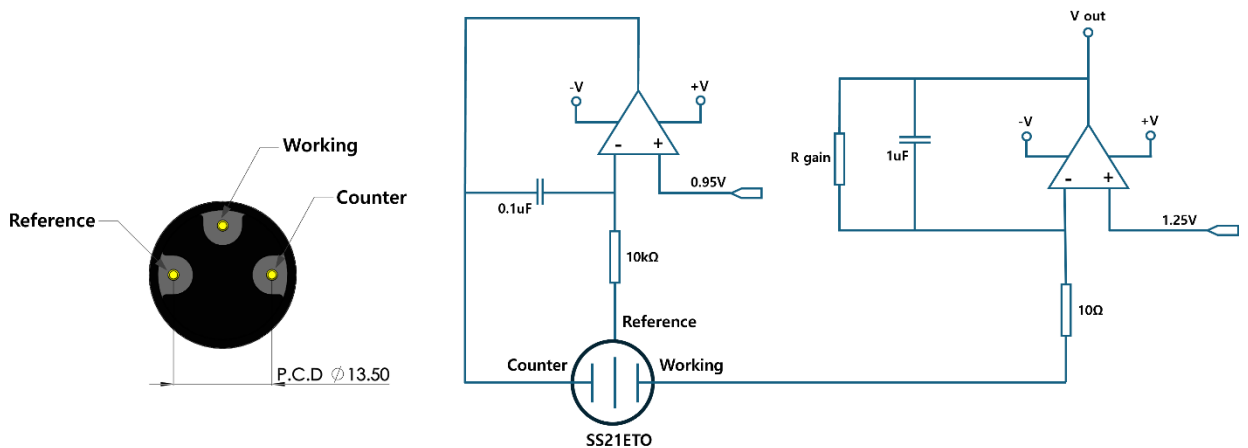

Due to ongoing research and product improvement, specifications are subject to change without notice.